



Gearmotor Selection and Application Guide

BODINE

ELECTRIC

COMPANY

bodine-electric.com

Gearmotor Benefits

- Gearmotors eliminate the need for motor/gearhead couplings and eliminate any potential bearing alignment problems.
- Quieter operation and “near perfect” alignment of the rotor, pinion and geartrain.
- Using the right sized motor and gearhead combination for an application helps to prolong gearmotor life and allows for optimum power management and power utilization.
- Minimum risk of lubricant leakage, because of “O-ring” and lip seal construction.

What is a Gearmotor?

A gearmotor (or geared motor) is a small electric motor (AC induction, permanent magnet DC, or brushless DC) designed with an integral (non-separable) gear reducer (gearhead) attached.

The **end shield** on the drive end of the motor is designed to provide a dual function. The side facing the motor provides the armature/rotor bearing support and a sealing provision through which the integral rotor or armature shaft pinion passes. The other side of the motor end shield provides multiple bearing supports for the gearing itself, and a sealing and fastening provision for the gearhousing. This construction offers

many benefits for a user and eliminates the guesswork of sizing a motor and gear reducer on your own.

Gearmotors function as torque multipliers and speed reducers, requiring less motor power to drive a given load. The gear housing design, the gearing type, gear lubrication, and the specific mode of integration all affect the gearmotor performance.

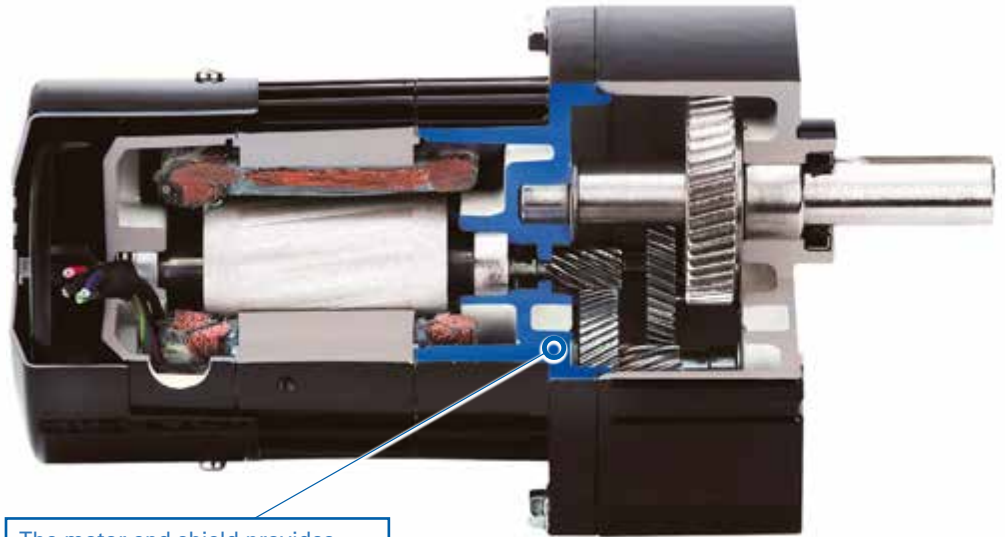

The motor end shield provides support and sealing for the gearhead and motor components.



Selecting the Right Gearmotor

Consider these basic design criteria to determine which gearmotor is right for your application.



Intermittent vs. Continuous Duty.

If the gearmotor will operate for only a few minutes or hours per day, consider the peak torque rating, and select the smallest gearmotor available. It will require less mounting space, and likely will be the most cost-effective solution. If the application requires a gearmotor for continuous duty operation, then choose one with a torque rating that is higher than the expected application torque.



Speed and Torque.

Once the duty cycle of the application has been determined, the two most important specs are desired speed and torque. Gearboxes reduce motor speed and multiply torque. When choosing a gearmotor for a specific application, consider the rated (max) speed and available torque that are listed on the gearbox's nameplate.



Gearhead Life.

Gearhead life depends on output torque, start/stop frequency, shock loads, operating speed, actual load and operating temperature. Talk to one of our application engineers about design life estimates.



Output Torque.

If your required torque exceeds the rated torque of the gearmotor, it can negatively affect the design life (see sidebar). While our integral gearmotors are designed for optimum performance at rated speed and torque, some manufacturers mate stand-alone motors and separable gear reducers, each with their own nameplate ratings. Motor/gearhead mismatch can greatly limit the gearmotor's life.



Brush Life.

Brush maintenance is only a concern with PMDC, universal or series wound DC motors. Brush life is dependent on variables such as motor speed and the form factor of the DC voltage.



Ambient Temperature.

The winding temperature plus the ambient temperature must be lower than the insulation class temperature limit. If there is no ambient temperature rating given on the nameplate, then ask the manufacturer. As a general rule, both lubricant and insulation life are cut in half for every 10°C increase in operating temperature above rated temperature.

Calculations

Calculating the Output Torque of a Motor-Reducer Combination

$$\text{Output torque} = T_m \times R \times \text{Eff}$$

T_m = Motor Torque

R = Gear Ratio

EFF = Gear Efficiency

(assume 80% gear efficiency)

Example 1

Reducer: 100 lb-in, 20:1 ratio

Motor: 10 oz-in @ 1,700 rpm

Result: 10 lb-in output torque

The mating of a 100 lb-in, 20:1 gear reducer to a 10 oz-in at 1700 rpm (1/60 HP) motor produces only a 10 lb-in output torque. This can mean overheating, slower output speed, or a gearmotor that can't even start the load.

Example 2

Reducer: 100 lb-in, 20:1 ratio

Motor: 300 oz-in @ 1,700 rpm

Result: 300 lb-in theoretical output torque

If the same gear reducer is mated to a motor rated 300 oz-in at 1,700 rpm (1/2 HP), then the output torque would be 300 lb-in, which is three times the rating of the gear reducer. This overloading of the gear reducer will greatly decrease its actual life.



Design Considerations for Gearmotor Applications

Application Tips

Oil vs. Grease

Oil provides more consistent lubrication to the gear teeth under load conditions. Grease provides greater flexibility in mounting and minimizes the risk of leakage. Despite advantages, oil is not always used in smaller fractional HP gearmotors because of these sealing considerations. If a non-standard mounting orientation is required, one possible alternative is a semi-fluid grease. Avoid mounting an oil-filled gearbox directly above the motor. If the drive shaft must point upward, then a grease-lubricated, right angle gearmotor would be a better solution.

When to Use Holding Brakes

In applications where a load has to be held securely during a power-off condition, an external holding brake should be added to the motor or gearmotor. The brake is typically installed on the high-speed or accessory shaft (armature or rotor shaft) and not on the drive shaft (output shaft).

Signs of Bearing Wear

Some early warning signs for bearing problems can be an increase in temperature differential between the motor and the bearings, an increase in bearing noise, or an increase in torque (load) of the motor, resulting in an increased current draw by the motor/gearmotor.

Now that you selected an (integral) gearmotor that meets your speed, torque, duty cycle and general performance criteria, consider these application specific questions:

Preferred gearmotor mounting orientations



Gearmotor Mounting Orientation.

Gearmotors are typically designed to be mounted with the gearbox level with the motor, and with the drive shaft in horizontal orientation. Other mounting positions are possible, depending on the type of gearmotor and how its gearbox is lubricated. If you require non-standard mounting (e.g. vertical), the first step in choosing a gearmotor should be to call the manufacturer's technical support team.

Typical Worm gear design

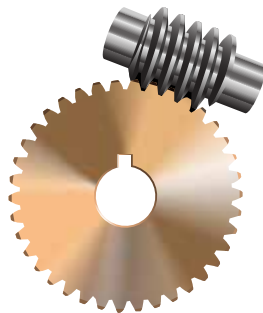

Gearhead Efficiency and Noise.

The worm gears found in most right angle gearboxes are generally quieter than the spur or helical gear assemblies used in parallel shaft or planetary gearboxes, but they are less efficient and generate more heat. Right angle gearmotors often require a larger motor to match the output torque of a parallel shaft gearmotor with the same gear ratio, but due to their compact design require less mounting space. Right angle gearmotors with gear ratios above 20:1 are often "self-locking," meaning they can't be back-driven. Right-angle gearboxes also can provide holding torque with the motor power turned off. This is

desirable in applications where a load is expected to remain stationary even after the power to the gearmotor is turned off. However, this is not recommended as a "fail-safe" application solution because holding torque diminishes as the gears become worn or if shaft vibration occurs.

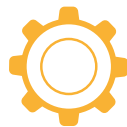

Gearhead Life.

Gearmotor life is affected by many factors. The obvious ones are operating speed, load, duty cycle, and ambient temperature. The higher any of these operating conditions are, the sooner the gearhead components will wear out. But there are also design details inside a gearbox that determine the gearmotor's life. For example: the sliding action of worm gears is more difficult to lubricate and is less efficient than the rolling action of spur and helical gearing. Therefore, metallic worm and gear teeth will wear faster than metallic spur and helical gear teeth. Oil lubricated gears will last longer than grease lubricated gears because oil provides more consistent lubrication to the gear teeth under load conditions.

Fractional HP Gearmotors Types and Benefits



Variable and Fixed Speed AC

Highly Efficient, Long Lasting Performance

- No maintenance required
- Inverter duty, 3-phase models are available with either 230V or 230/460 VAC windings



Brushless DC (EC) and INTEGRAmotors

Quiet Running, Zero Maintenance

- 24 or 130VDC windings
- INTEGRAmotors feature a low-voltage brushless DC speed control, motor and encoder in one compact package.



Permanent Magnet DC

Variable Speed, Easy to Install

- High starting torque and predictable linear speed torque performance
- Easy control set-up



Hollow Shaft Gearmotors

Eliminate Sprockets, Couplings and Drive Chains

- Versatile mounting options in tight spaces
- Easier to mount and maintain than regular right-angle gearmotors
- Available in AC, PMDC or BLDC configurations

GEARMOTOR OPTIONS

Commonly Used Calculations

Gearmotor Torque

Gearmotor torque (output) when motor torque is known

$$T \text{ [lb-in]} = \frac{(T_m - SF) \text{ [oz-in]}}{16} \times R \times \text{Eff}$$

T_m = Motor Torque
 SF = Seal Friction
 R = Ratio
 Eff = Efficiency

Motor HP Formula

Motor horsepower for a given torque and speed

$$\text{HP} = \frac{T_m \text{ (oz-in)} \times N \text{ (RPM)}}{63025 \times 16}$$

N = Motor Speed

Motor Torque Formula

Motor torque for a given horsepower rating

$$T_m \text{ [oz-in]} = \frac{\text{HP} \times 63025 \times 16}{N \text{ (RPM)}}$$

HP = Motor Power

AC Motor Speed Calculation

$$\text{Speed [RPM]} = \frac{120 \times \text{Hz}}{\text{Number of Poles}} \text{ (-Slip)*}$$

*Slip only applies to non-synchronous AC Motors

Common Conversions

1 HP = 746 Watts
 1 lb-in = 16 oz-in
 1 lb = 0.454 Kg
 1 lb-in = 0.113 Nm

Custom Gearmotors Solve AGV Challenge



The Design Requirement

Bodine was asked to design, test, and manufacture two custom gearmotors under tight deadlines and with challenging requirements.

The Solution

Our engineering team developed two new gearmotors that met the customer's performance, cost, and delivery targets.

An original equipment manufacturer (OEM) for AGVs specifications required two gearmotors, one of them had to lift up to 1,000 lbs (with substantial peak loads). The AGV's chassis had already been finalized, with limited space for the new gearmotors. The gearmotors were required to operate almost continuously for five years, under worst-case environmental conditions, and would be subjected to extreme vibration and shock.

The Result

Almost every part of these new gearmotors was engineered to match the customer's extensive list of requirements.

- Low-Voltage brushless DC gearmotors
- Custom gearbox designs optimized for efficiency
- Custom output shaft assembly
- Feedback device (1024 PPR encoder)
- Temperature sensors

Custom Bodine **type 34B-CG**
parallel shaft gearmotor



Custom Bodine **type 22B-Z**
parallel shaft gearmotor



AC Synchronous Gearmotors Simplify Design



The Design Requirement

A manufacturer of an automated bag sealer required that two conveyors within the same machine operate at synchronous speeds.

The Solution

- Each conveyor is driven by a synchronous AC inverter duty gearmotor
- One AC speed control (VFD) was used to precisely sync both gearmotors

Automated Bag Sealer

Continuous band polybag sealers typically have two driven conveyors. To insure that both top and bottom run at precisely the same speed the two conveyors are frequently coupled together with chains and sprockets.

Our design team worked with a packaging equipment OEM manufacturer on a solution that radically simplified their design. The team suggested that each conveyor should have its own gearmotor, synced to a single AC speed control. This eliminated the bulky chain and sprocket assembly and feedback devices.

This design took advantage of the unique properties of custom Bodine type 30R-D (top) and 34R-WX AC (bottom) synchronous gearmotors.



Quiet Gearmotors for Medical Equipment



The Design Requirement

To minimize patient anxiety, a medical equipment manufacturer requested extremely smooth and quiet operation of the gearmotors in their equipment.

The Solution

- Bodine engineers identified four key aspects of gearmotor design that contribute to quiet operation
- Helped the OEM manufacturer to select the best gearmotor solution for their machine

Bodine type 33A-5L/H hollow shaft right angle gearmotor with worm gearing.



Worm Gearing

The sliding tooth action of worm gearing is generally quieter than the rolling action of spur and helical gearing. A second advantage for the application was that worm gears lock in place when there is no power to the gearmotor.

Ball Bearings

Our engineers recommended ball bearings to minimize thrust loads on the driveshaft. Thrust loads can make the driveshaft shift back and forth within the gearbox. Ball bearings are pressed onto the driveshaft, locking it in place.



Bodine Manufacturing Plant, Iowa

Gearmotors For Applications Where Good Enough is Simply Not Good Enough!

When you choose a Bodine gearmotor, motor or control you get more than just the nameplate ratings. You get peace of mind. Whether you are designing a new machine or simply upgrading existing machinery, you can count on our team to make sure you have a motion control solution that will be reliable, efficient, and trouble-free for years to come. We design our rugged, high-performance gearmotors for equipment where downtime is not an option.

Bodine offers over 1,300 standard/stock products with gear ratios from 4:1 to 3600:1, torque to 1000 lb-in (113Nm) and horsepower up to $\frac{3}{4}$ hp (560W), all available from our centrally-located manufacturing facility in Peosta, Iowa. If none of our stock products fit your needs, let our engineers help you create a custom solution that precisely matches your design specifications.

Bodine Electric Company
201 Northfield Road
Northfield, IL 60093 U.S.A.
Tel: 773.478.3515
info@bodine-electric.com



bodine-electric.com