

4

3

2

1

BODINE ELECTRIC COMPANY

PART NO./REV: INFM0256 A

NOTES:

1. TORQUE SCREWS TO ATTACH MODEL 5968 BRACKET TO GEARMOTOR WITH 30 LB-IN

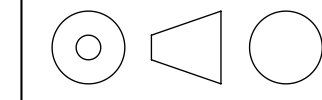

DESCRIPTION:
GEARMOTOR 22B3BEBL/FV-D3 &
22B3BEBL/SR-D3/4/5 WITH BRACKET

| | | |
|----------|-----|---------------------------------|
| SHEET: | 1/1 | UNLESS OTHERWISE SPECIFIED: |
| SCALE: | 1:1 | UNITS ARE IN INCHES [mm] |
| C | | TOLERANCES: .XX:±.01 .XXX:±.005 |
| | | ANGLES: X°:±3° X.X°:±0.5° |

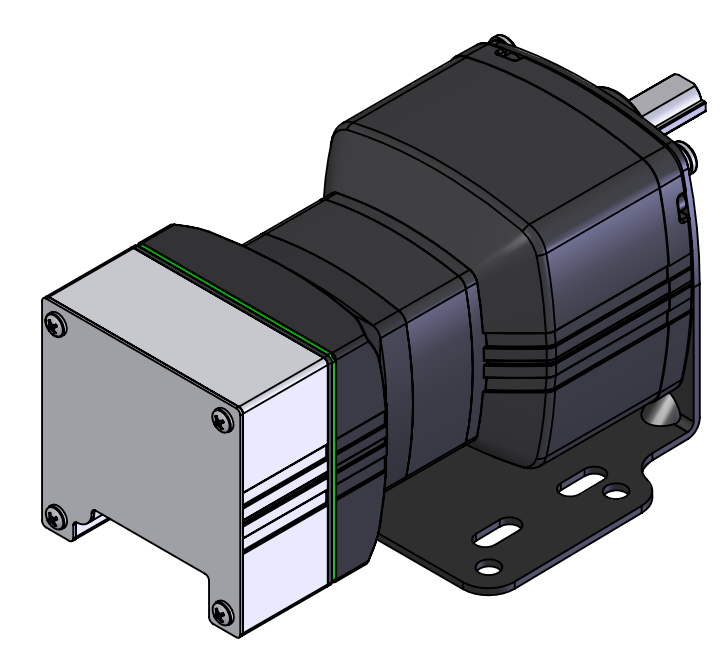
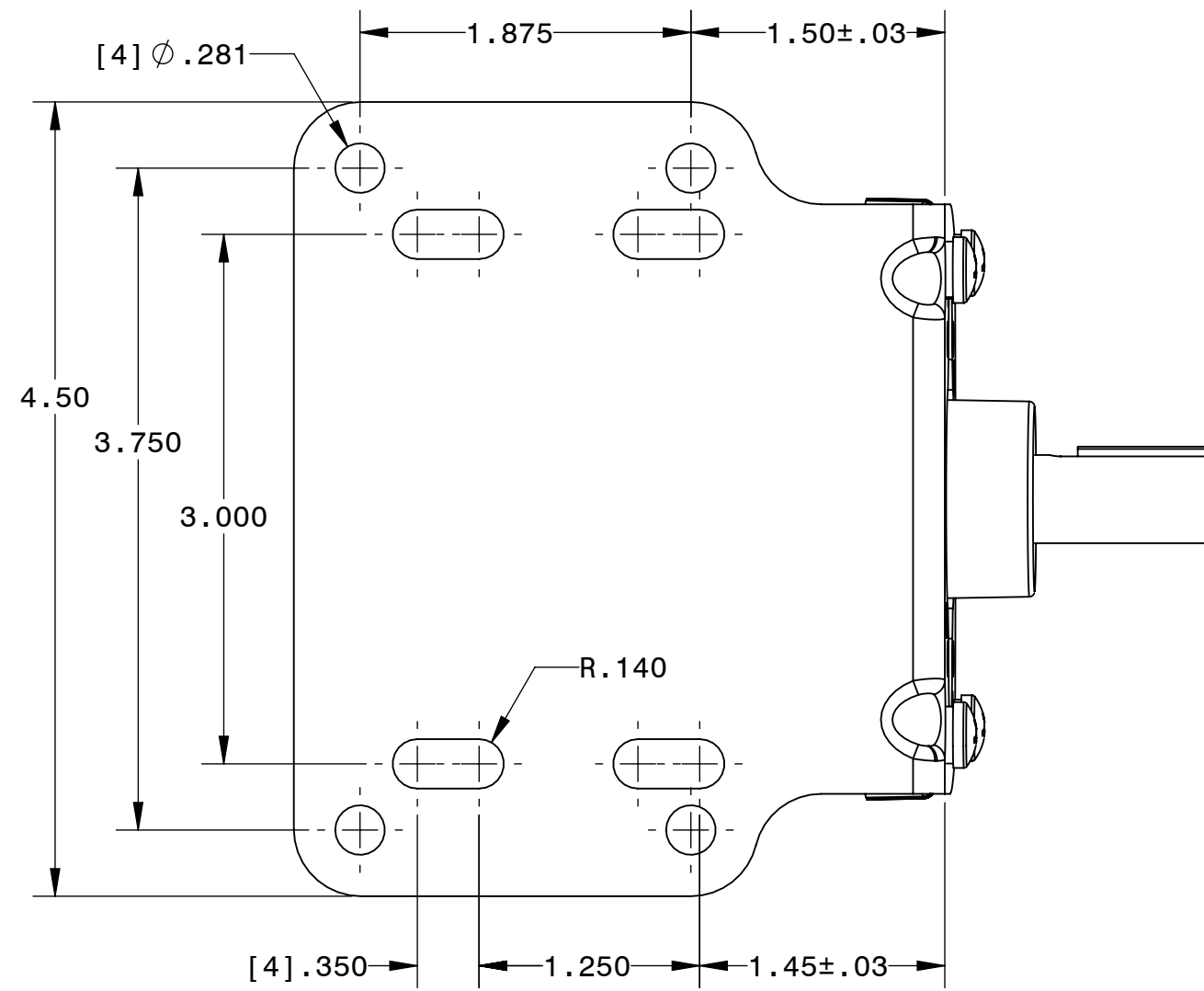
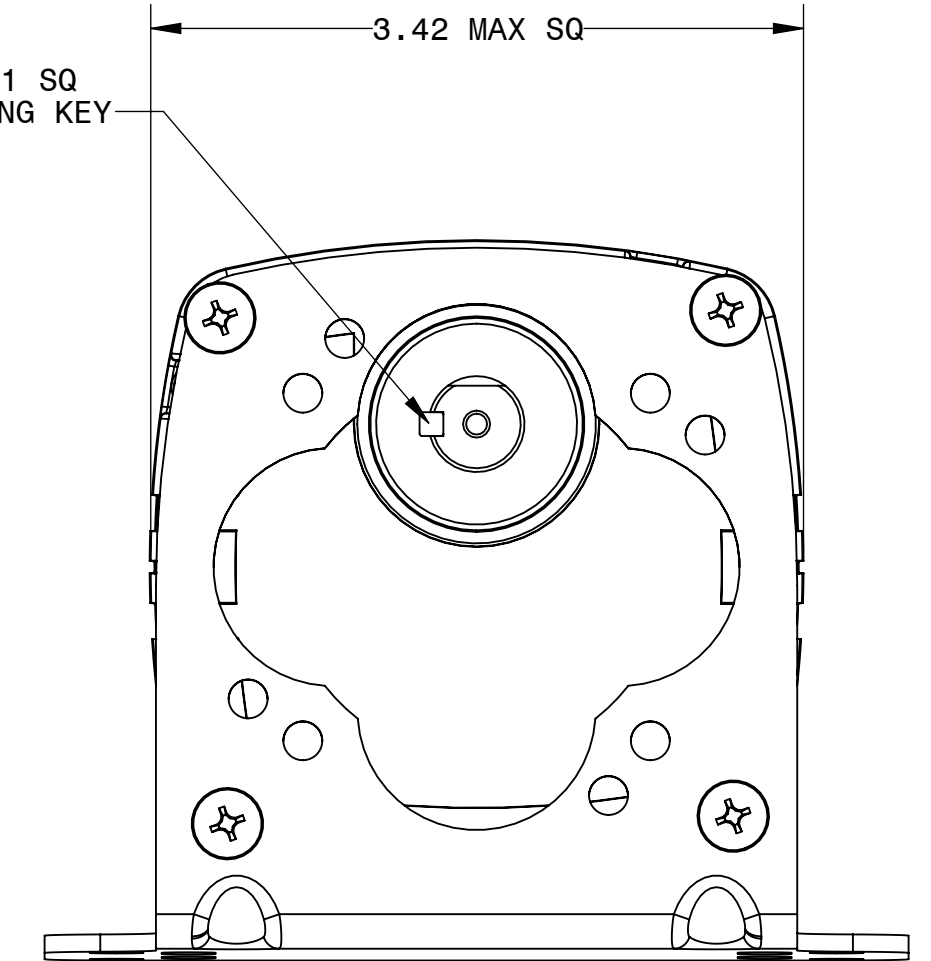
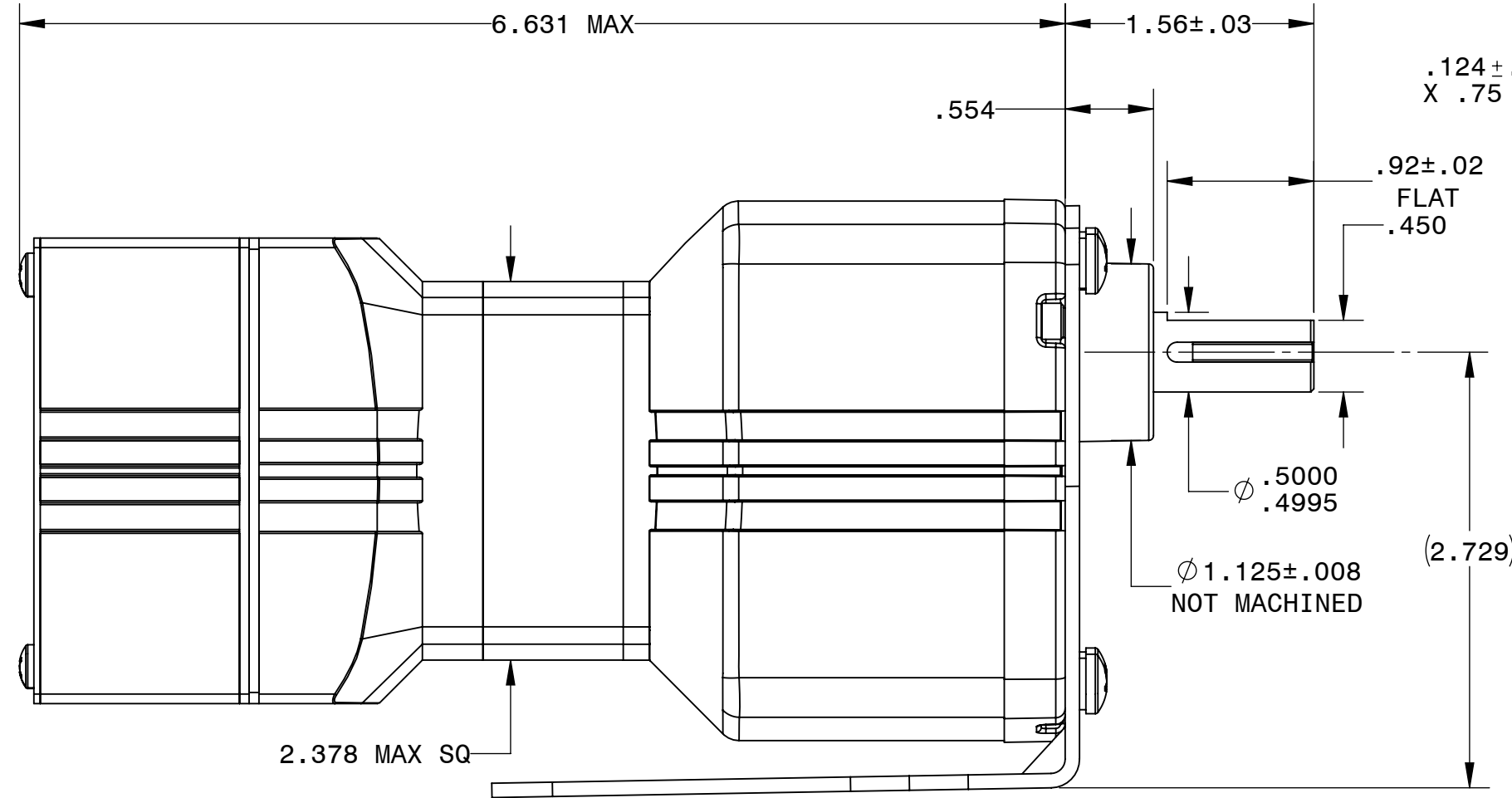
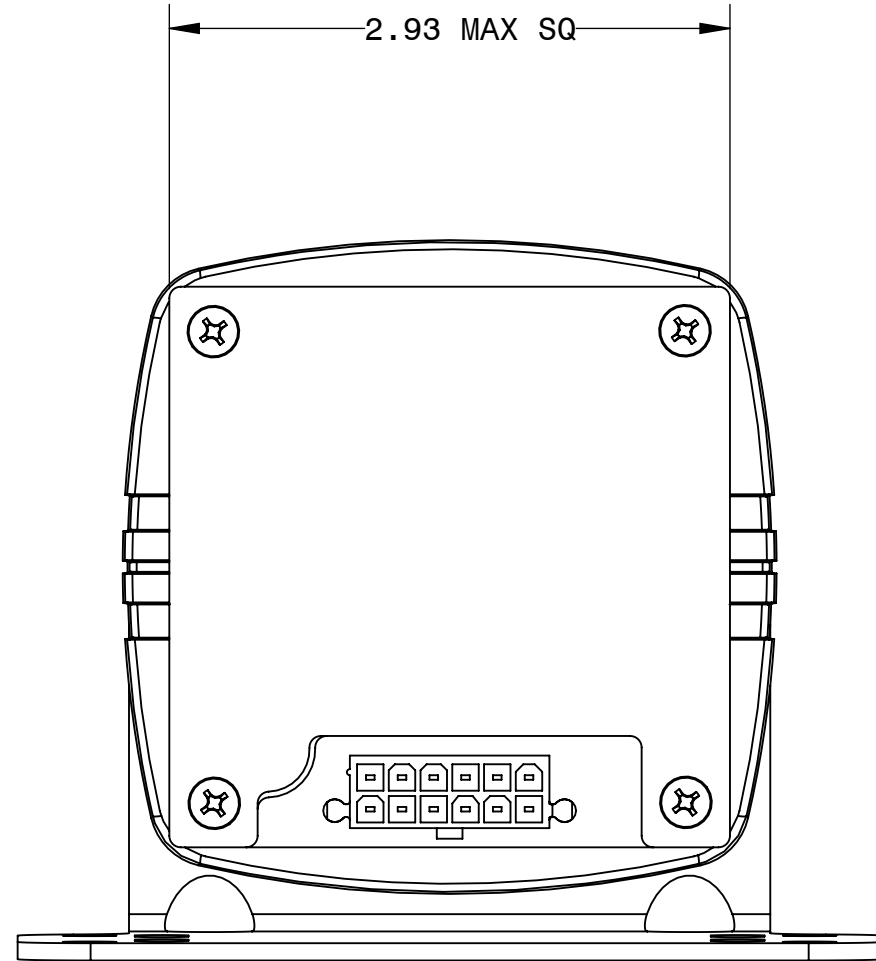

REPRESENTATIVE OF MODEL NUMBER(S): [WITH OPTIONAL BRACKET MODEL 5968]

3726 3727 3728 3729 3734 3735 3736 3737 3826 3827 3828 3829 3834 3835 3836 3837

4

3

2

1