

4

3

2

1

BODINE ELECTRIC COMPANY

PART NO./REV: INFM0296 A

NOTES:
1. TORQUE SCREWS TO ATTACH MODEL 5968 BRACKET TO GEARMOTOR WITH 30 LB-IN

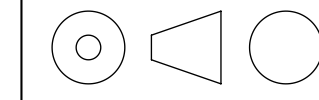

DESCRIPTION: GEARMOTOR 30R2BEPP/CI-D3/4 WITH L BRACKET	
SHEET: 1/1	UNLESS OTHERWISE SPECIFIED:
SCALE: 1:1	UNITS ARE IN INCHES [mm]
C	TOLERANCES: .XX:±.01 .XXX:±.005 ANGLES: X°:±3° X.X°:±0.5°

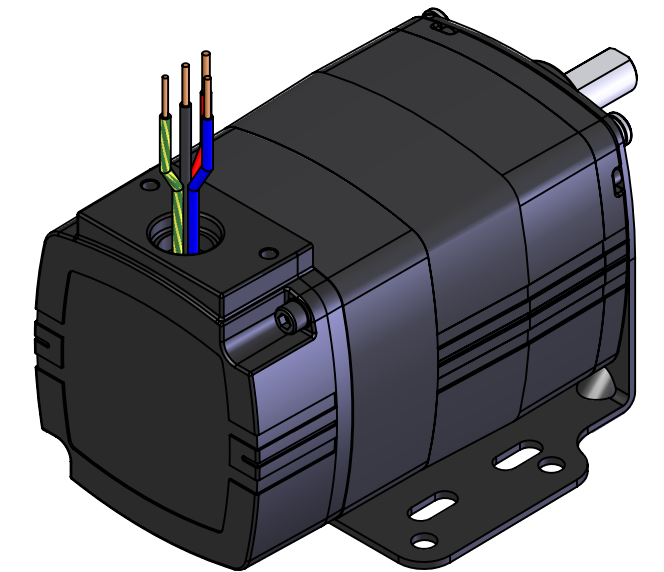
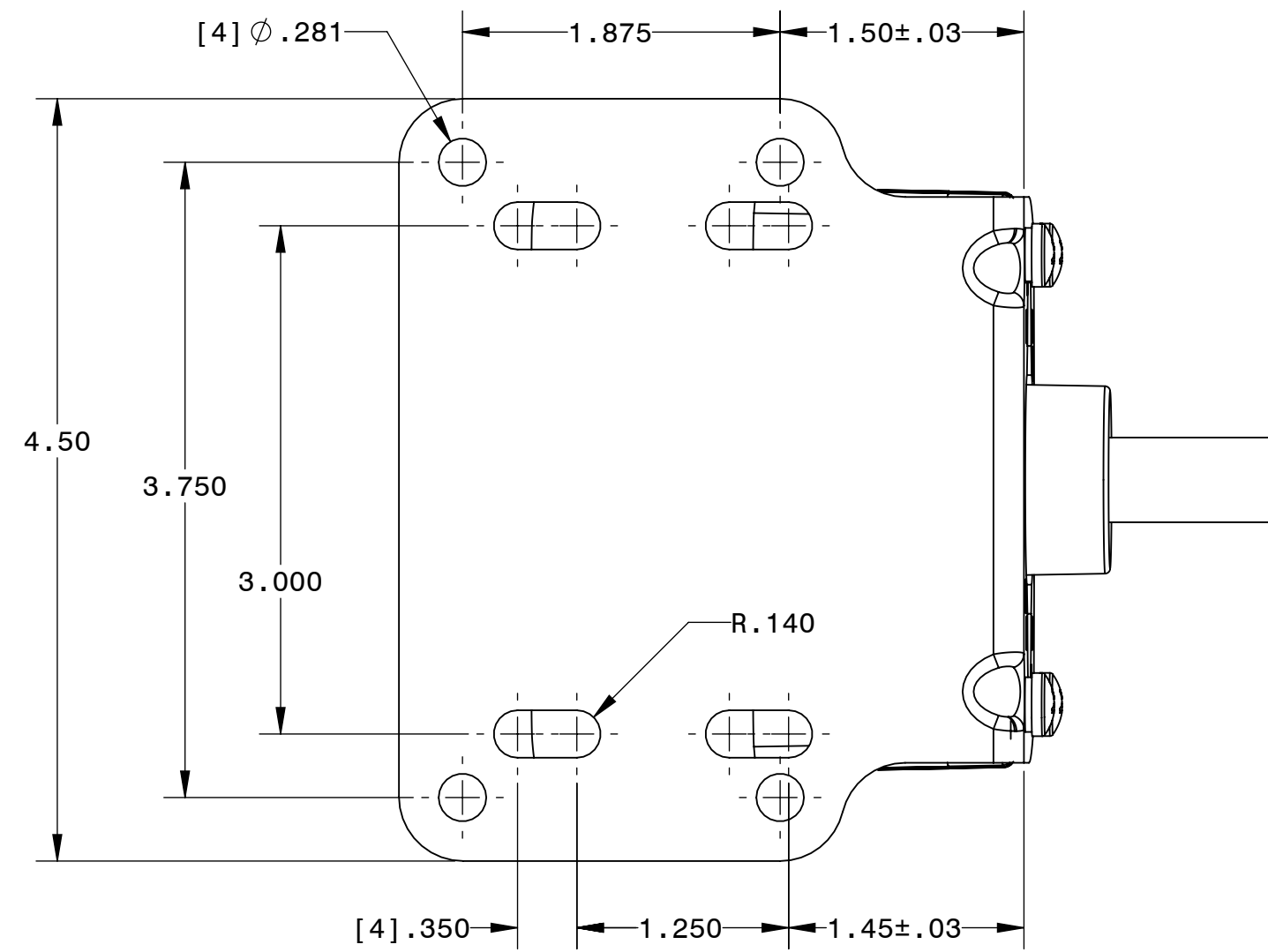
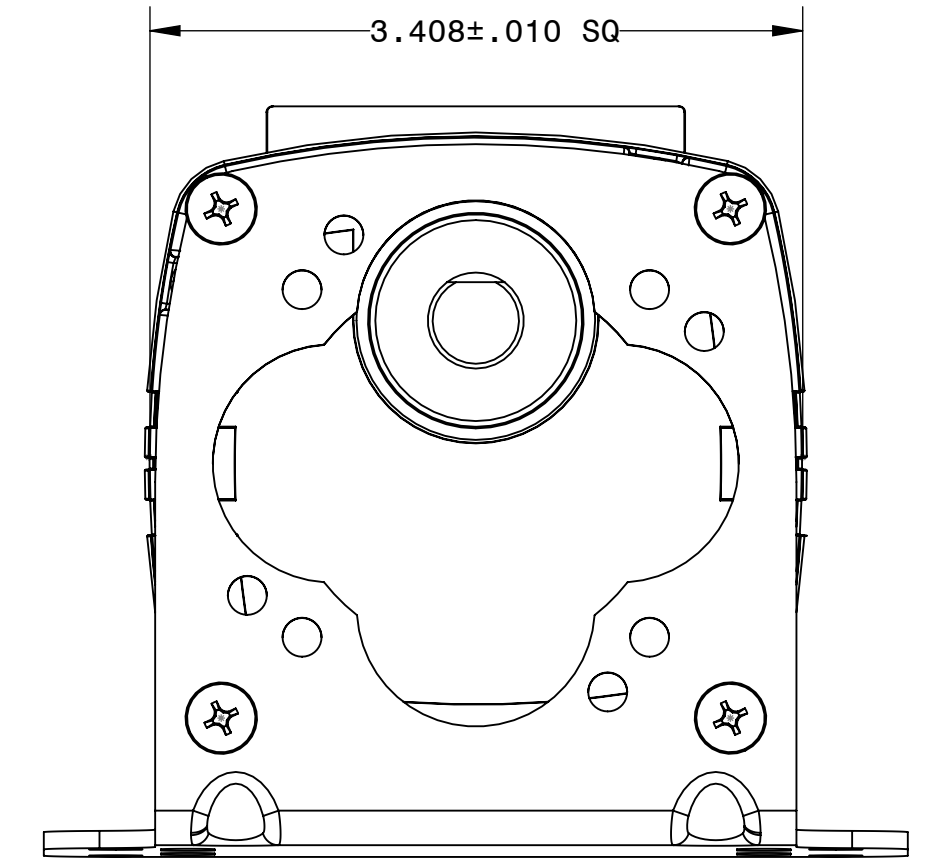
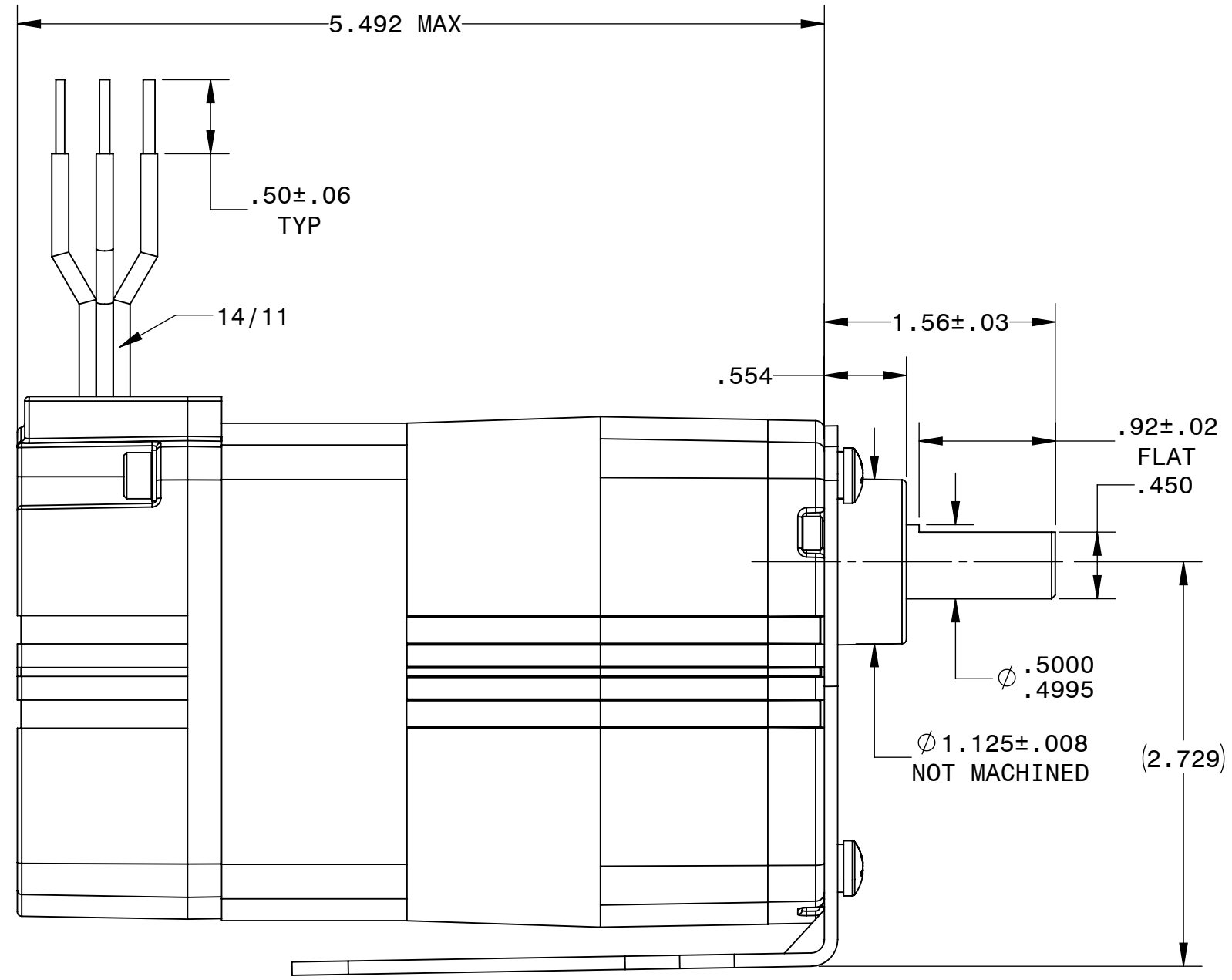
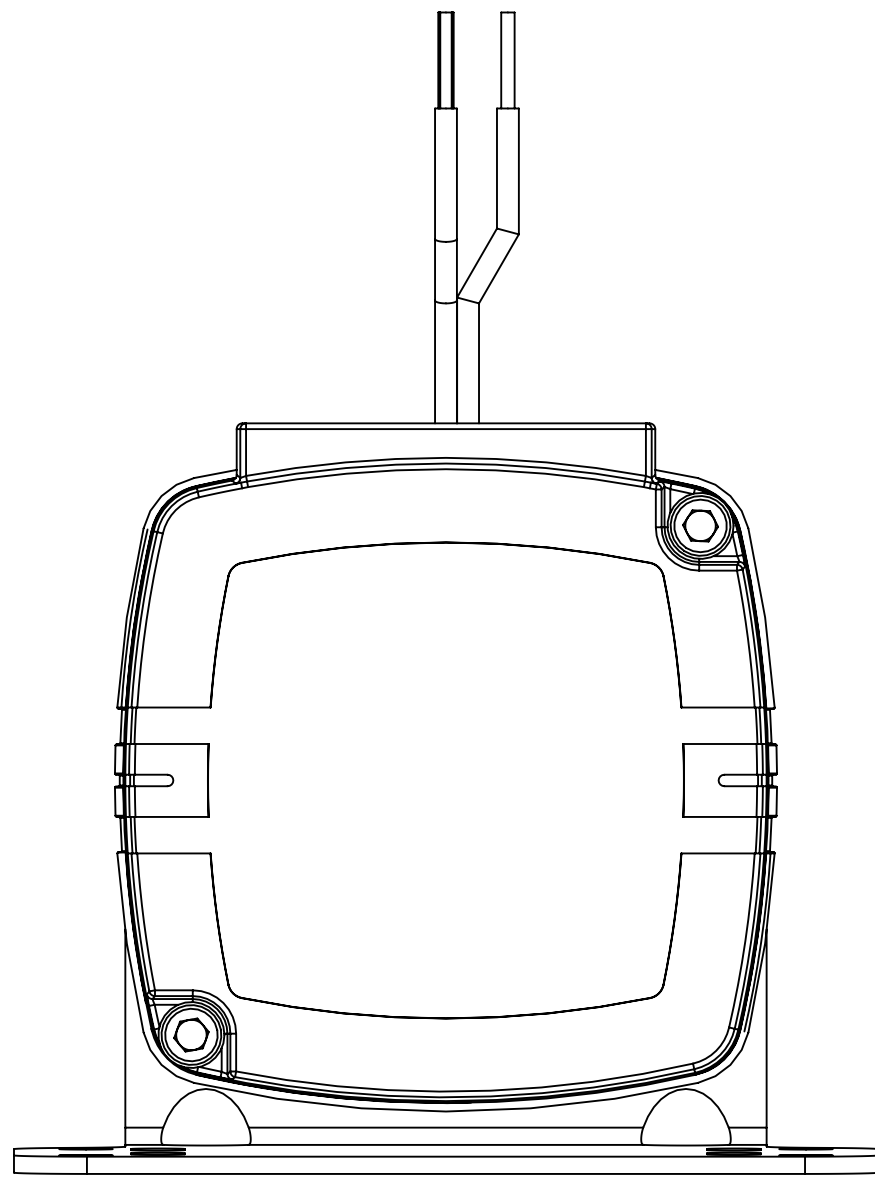

REPRESENTATIVE OF MODEL NUMBER(S): [WITH OPTIONAL BRACKET MODEL 5968]

2210 2212 2214 5470 5471 5472 5473 5474

4

3

2

1