

4

3

2

1

BODINE ELECTRIC COMPANY

PART NO./REV: INFM0302 A

NOTES:
1. TORQUE SCREWS TO ATTACH MODEL 5968 BRACKET TO GEARMOTOR WITH 30 LB-IN

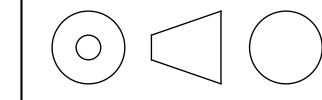

DESCRIPTION:
GEARMOTOR 24A4FEPM-D3/4/5
WITH L BRACKET

SHEET:	1/1	UNLESS OTHERWISE SPECIFIED:
SCALE:	1:1	UNITS ARE IN INCHES [mm]
C		TOLERANCES: .XX:±.01 .XXX:±.005
		ANGLES: X°:±3° X.X°:±0.5°

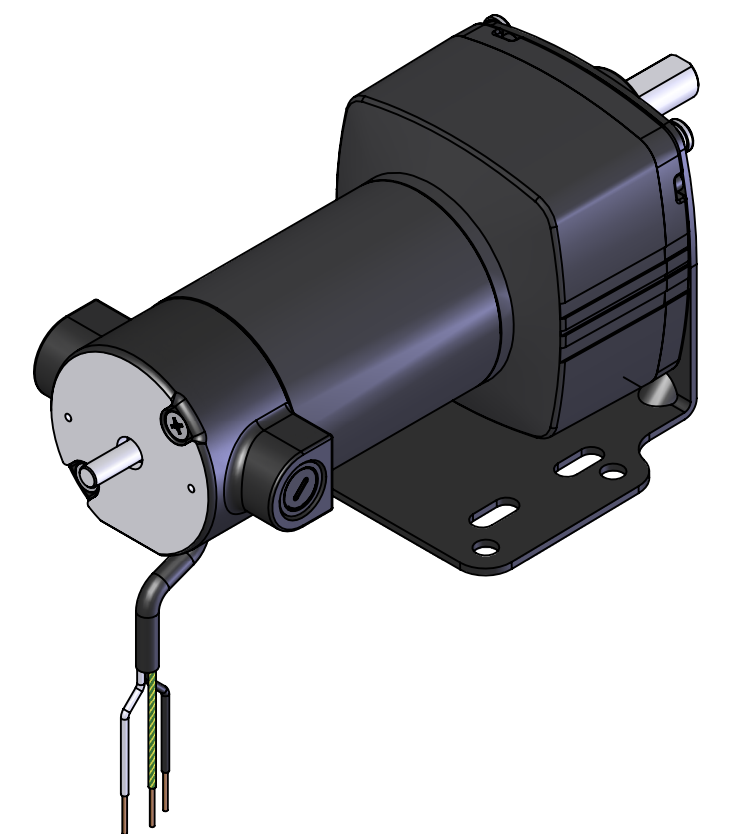
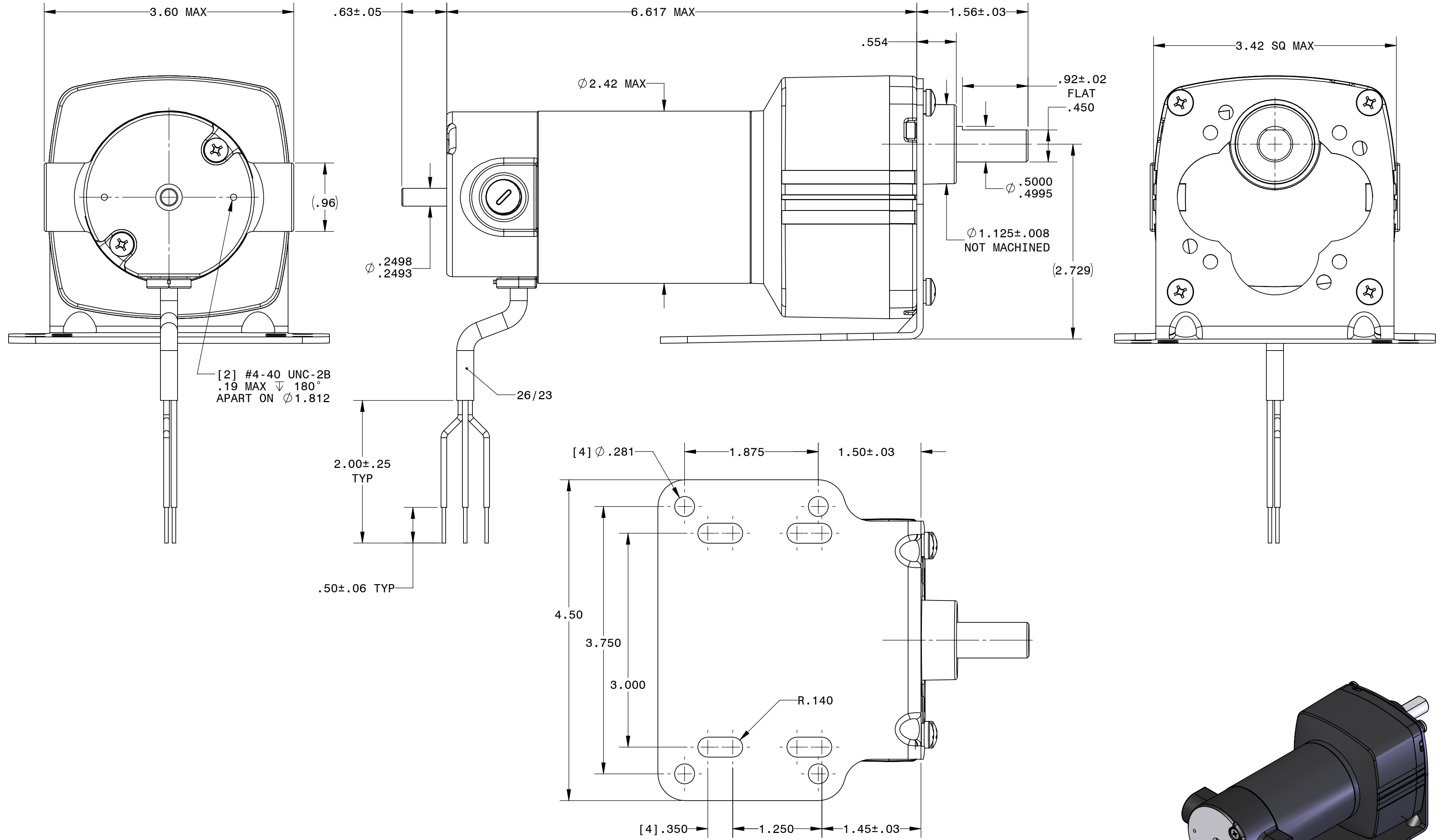

REPRESENTATIVE OF MODEL NUMBER(S): [WITH OPTIONAL BRACKET MODEL 5968]

4487

4

3

2

1