

NOTES:
 1. TORQUE SCREWS TO ATTACH MODEL 0980 BRACKET TO GEARMOTOR WITH 30 LB-IN

BODINE ELECTRIC COMPANY

PART NO./REV:	INFM0307	A
DESCRIPTION:	GEARMOTOR 34R6BF-Z3/4 WITH L BRACKET	
SHEET:	1/1	UNLESS OTHERWISE SPECIFIED:
SCALE:	1:2	UNITS ARE IN INCHES [mm]
B		TOLERANCES: .XX:±.01 .XXX:±.005
		ANGLES: X°:±3° X.X°:±0.5°

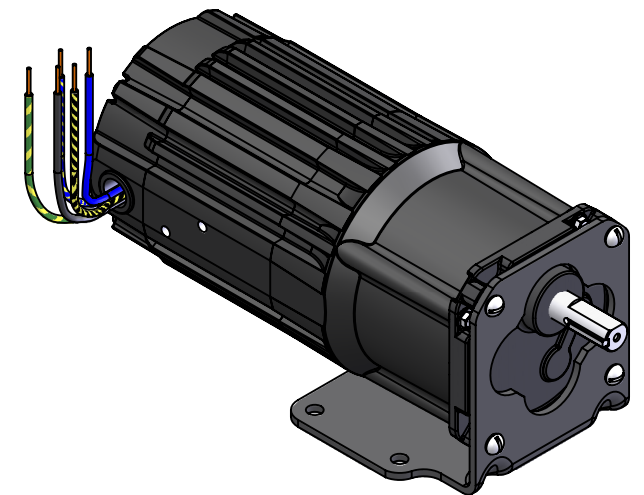
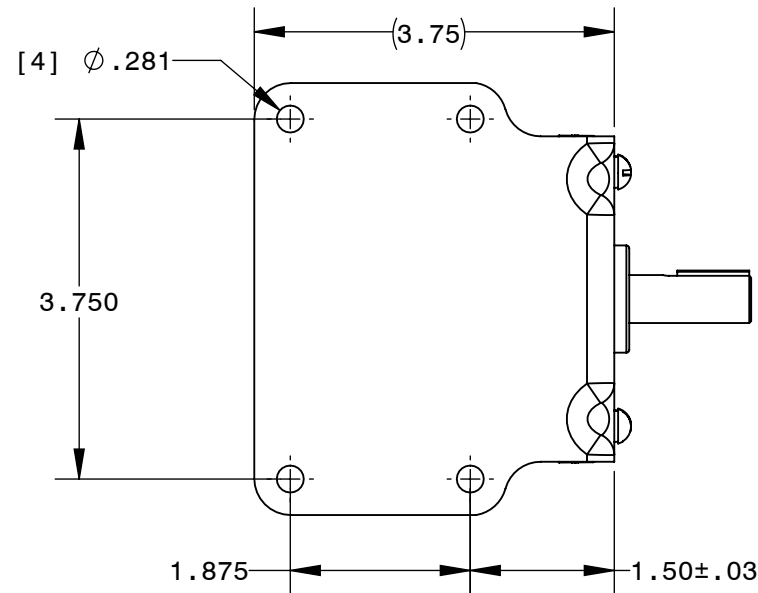
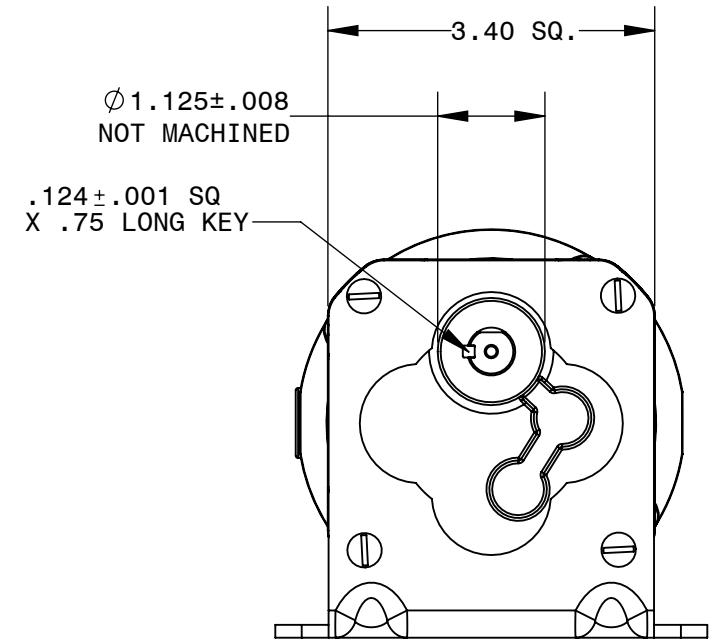
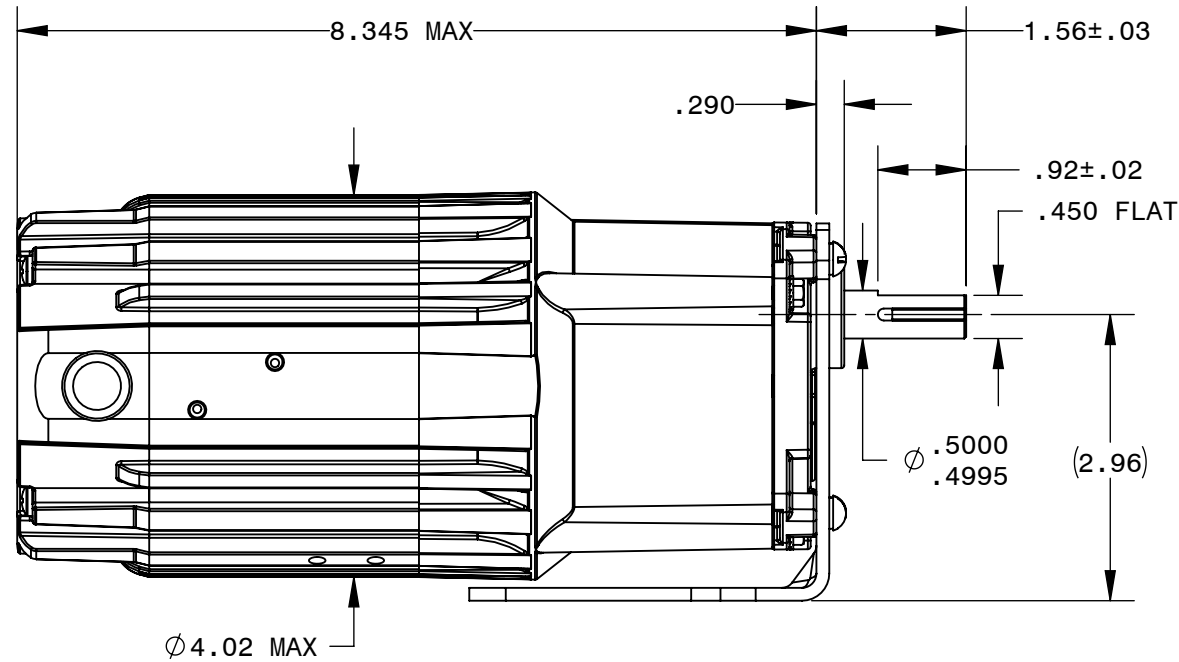
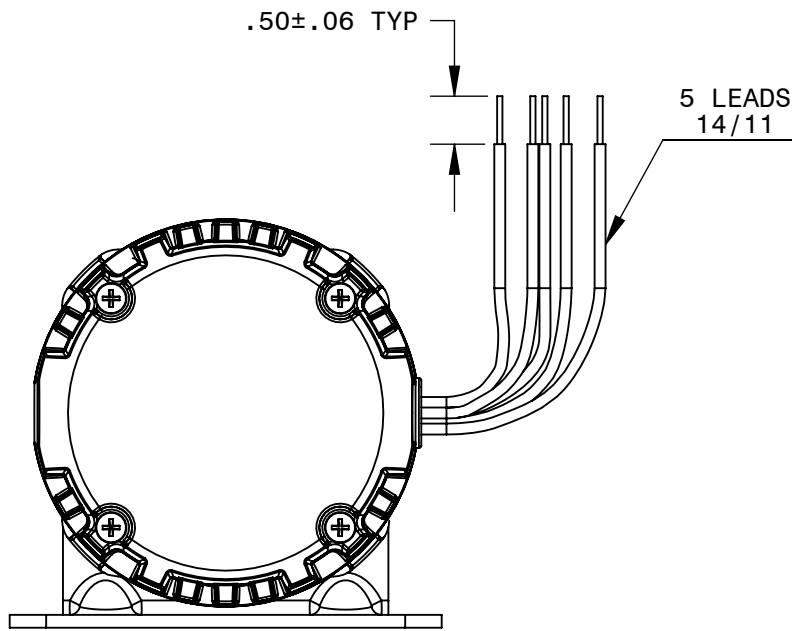
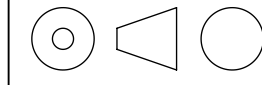

REPRESENTATIVE OF MODEL NUMBER(S): [WITH OPTIONAL BRACKET MODEL 0980]

2220 2222 2224 2226