

Installation Instructions for Optional L-Bracket Kits Model 0970 or Metric Model 1970 for WX (or W) Gearmotors

Purchase Date _____

© Copyright 2019 Bodine Electric Company
 Data subject to change without notice.

Installed By _____

Parts Description

One set of (4) four screws and (4) four lockwashers are included in each kit to mount the gearmotor to the bracket (model 0970 with [4] 1/4-28, model 1970 with [4] M5 hex head cap screws). The (4) slots in the base of the L-bracket are .281 wide. The slots in the base of the bracket accommodate .250 inch diameter fasteners (supplied by the user) to secure the bracket to the mounting surface.

in any position. For permanent magnet DC motors, the preferred mounting position is with the brushes horizontal as shown below. In most applications it will be preferable to mount the gearmotor with the drive shaft in the 12 o'clock position as shown below. If the motor is mounted with the lead exit facing the mounting surface there may not be adequate clearance for the cord and bushing between the motor and the mounting surface.

The screw supplied should be tightened to 30 lb-in. torque.

To minimize L-bracket deflection, the maximum permissible overhung load is 125 pounds.

Mounting Instructions

The L-bracket can be attached to a WX gearmotor for mounting

Example: Type 33A-WX Gearmotor with Model 0970 L-Bracket Installed (inches)

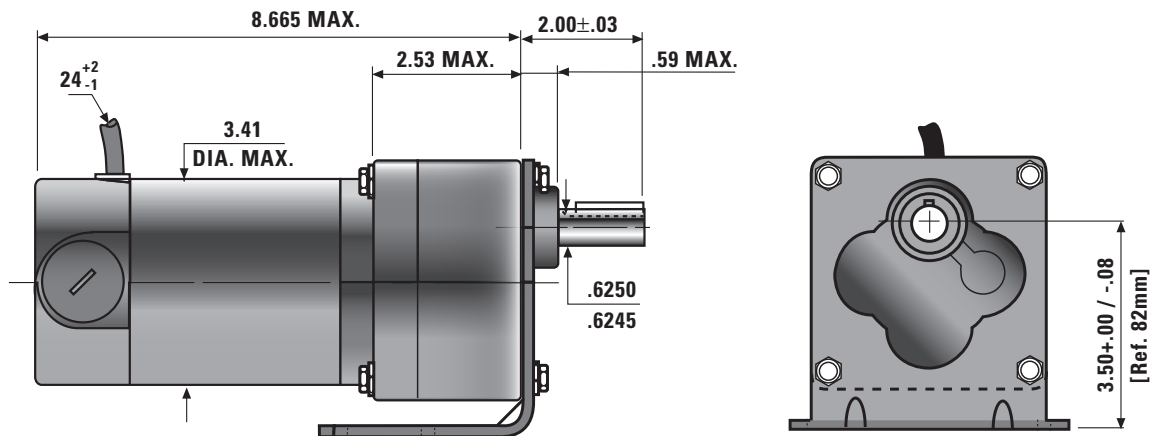

Model 0970 L-Bracket Dimensions (inches)

