



SCR Rated 90V and 180V DC Gearmotors

To provide greater flexibility and compatibility with unfiltered SCR controls, Bodine Electric Company now offers a new selection of 90V and 180VDC gearmotors with a maximum rated armature speed of 2500 rpm. These new SCR rated stock models from Bodine can replace 90V or 180VDC gearmotors sold by Baldor, Bison Gear, Leeson, or Grainger.



Type 24A-Z SCR Rated



Type 33A-Z SCR Rated



Type 33A-WX SCR Rated



Type 42A-FX SCR Rated



Type 33A-5L/H SCR Rated

Rated Speed (rpm) ¹	Rated Torque (lb-in.)	Rated Current (Amps)		Form Factor		Motor HP		Gear Ratio	Peak Torque (lb-in.)	Radial Load (lbs.)	Product Type	Model Number	
		90V	180V	90V	180V	90V	180V					90V	180V

Type 24A-Z Parallel Shaft Gearmotors | Up to 120 lb-in.

14	120	0.58	0.3	1.6	1.5	1/20	1/19	180:1	139	166	24A4BEPM-Z4	1245	1236
28	77	0.58	0.3	1.6	1.5	1/20	1/19	90:1	126	193	24A4BEPM-Z4	1243	1235
42	55	0.58	0.3	1.6	1.5	1/20	1/19	60:1	137	207	24A4BEPM-Z3	1242	1234
83	27	0.58	0.3	1.6	1.5	1/20	1/19	30:1	120	225	24A4BEPM-Z3	1241	1233
139	18	0.58	0.3	1.6	1.5	1/20	1/19	18:1	48	142	24A4BEPM-Z2	1239	1232
208	12	0.58	0.3	1.6	1.5	1/20	1/19	12:1	44	145	24A4BEPM-Z2	1238	1231
417	6	0.58	0.3	1.6	1.5	1/20	1/19	6:1	20	147	24A4BEPM-Z2	1237	1230

Type 33A-Z Parallel Shaft Gearmotors | Up to 120 lb-in.

42	120	1.6	0.8	1.4	1.4	1/7	1/7	60:1	137	166	33A5BEPM-Z3	1189	1179
83	87	1.6	0.8	1.4	1.4	1/7	1/7	30:1	120	187	33A5BEPM-Z3	1188	1178
139	39	1.6	0.8	1.4	1.4	1/7	1/7	18:1	48	132	33A5BEPM-Z2	1186	1177
208	36	1.6	0.8	1.4	1.4	1/7	1/7	12:1	44	132	33A5BEPM-Z2	1185	1176
417	19	1.6	0.8	1.4	1.4	1/7	1/7	6:1	20	137	33A5BEPM-Z2	1184	1175

Type 33A-WX Parallel Shaft Gearmotors | Up to 205 lb-in.

8.0	205	1.6	0.8	1.4	1.4	1/7	1/7	312:1	350	300	33A5BEPM-WX4	1259	1172
15	200	1.6	0.8	1.4	1.4	1/7	1/7	172:1	350	300	33A5BEPM-WX4	1247	1170
26	185	1.6	0.8	1.4	1.4	1/7	1/7	98:1	350	261	33A5BEPM-WX4	1257	1168
38	190	1.6	0.8	1.4	1.4	1/7	1/7	66:1	350	223	33A5BEPM-WX3	1256	1166
46	163	1.6	0.8	1.4	1.4	1/7	1/7	55:1	350	217	33A5BEPM-WX3	1255	1164
57	131	1.6	0.8	1.4	1.4	1/7	1/7	44:1	327	213	33A5BEPM-WX3	1254	1162
84	88	1.6	0.8	1.4	1.4	1/7	1/7	30:1	220	201	33A5BEPM-WX3	1253	1169
123	64	1.6	0.8	1.4	1.4	1/7	1/7	20:1	160	185	33A5BEPM-WX2	1252	1158
181	41	1.6	0.8	1.4	1.4	1/7	1/7	14:1	97	172	33A5BEPM-WX2	1251	1154
266	26	1.6	0.8	1.4	1.4	1/7	1/7	9:1	65	156	33A5BEPM-WX2	1250	1153
455	15	1.6	0.8	1.4	1.4	1/7	1/7	6:1	37	135	33A5BEPM-WX2	1249	1152
658	11	1.6	0.8	1.4	1.4	1/7	1/7	4:1	22	122	33A5BEPM-WX2	1248	1150

Type 42A-FX Parallel Shaft Gearmotors | Up to 350 lb-in.

8.3	350	2.2	1.2	1.5	1.6	1/4	1/4	300:1	500	214	42A5BEPM-FX4	1510	5149
14	350	2.2	1.2	1.5	1.6	1/4	1/4	180:1	500	214	42A5BEPM-FX4	1509	5148
21	350	2.2	1.2	1.5	1.6	1/4	1/4	120:1	500	214	42A5BEPM-FX4	1508	5147
42	290	2.2	1.2	1.5	1.6	1/4	1/4	60:1	470	233	42A5BEPM-FX3	1507	5146
63	194	2.2	1.2	1.5	1.6	1/4	1/4	40:1	335	254	42A5BEPM-FX3	1506	5145
83	145	2.2	1.2	1.5	1.6	1/4	1/4	30:1	400	281	42A5BEPM-FX3	1505	5144
125	97	2.2	1.2	1.5	1.6	1/4	1/4	20:1	280	292	42A5BEPM-FX3	1504	5143
167	73	2.2	1.2	1.5	1.6	1/4	1/4	15:1	290	300	42A5BEPM-FX2	1503	5142
250	48	2.2	1.2	1.5	1.6	1/4	1/4	10:1	195	300	42A5BEPM-FX2	1502	5141
500	25	2.2	1.2	1.5	1.6	1/4	1/4	5:1	72	48	42A5BEPM-FX1	1501	5140

Type 33A-5L/H Hollow Shaft Gearmotors | Up to 89 lb-in.

33	89	1.6	0.8	1.4	1.4	1/7	1/7	75:1	190	120	33A5BEPM-5L/H	1526	1516
63	68	1.6	0.8	1.4	1.4	1/7	1/7	40:1	177	120	33A5BEPM-5L/H	1525	1515
83	61	1.6	0.8	1.4	1.4	1/7	1/7	30:1	169	120	33A5BEPM-5L/H	1524	1514
125	47	1.6	0.8	1.4	1.4	1/7	1/7	20:1	159	120	33A5BEPM-5L/H	1523	1513
250	25	1.6	0.8	1.4	1.4	1/7	1/7	10:1	91	120	33A5BEPM-5L/H	1522	1512
500	14	1.6	0.8	1.4	1.4	1/7	1/7	5:1	49	120	33A5BEPM-5L/H	1521	1511

1. Rated speed is based on 2500 rpm armature speed at rated voltage.



Dimensions

Type 24A-Z and 33A-Z Parallel Shaft Gearmotors (Dimensions in Inches)

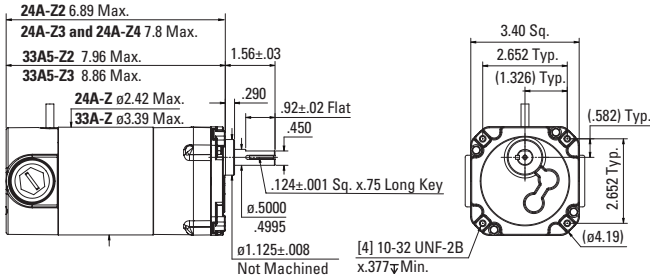

Model 5968 L-Bracket for Z Gearmotors (Dimensions in Inches)

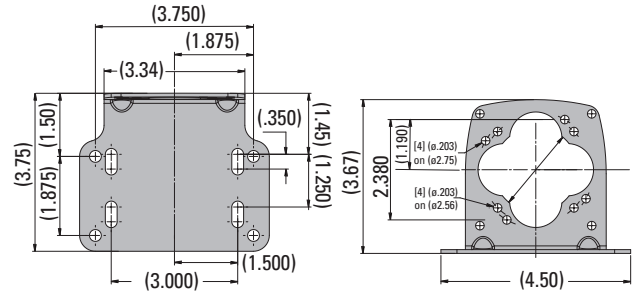

Type 33A-WX Parallel Shaft Gearmotors (Dimensions in Inches)

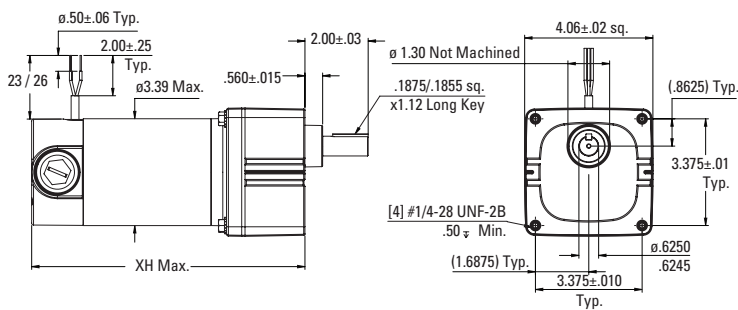

Type 42A-FX Parallel Shaft Gearmotors (Dimensions in Inches)

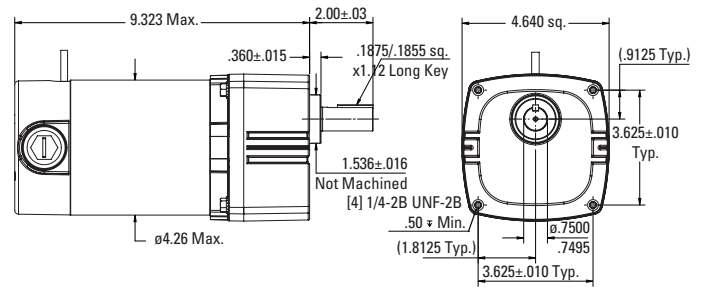

Type 33A-5L/H Hollow Shaft Gearmotors (Dimensions in Inches)

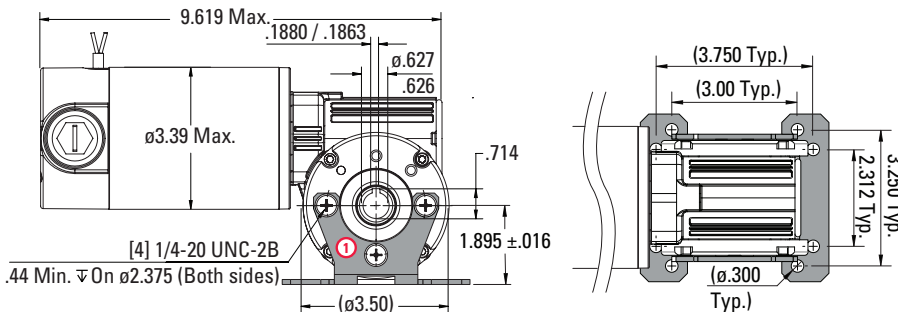

Model 0956 Flange Kit also available.

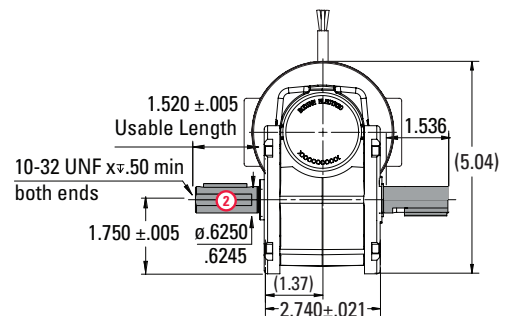

① Shown with optional Model 0958 Base Kit for a Baldor & Bison mounting pattern.

② Shown with optional Model 0922 5/8" Double Shaft Kit. Model 0912 5/8 inch Single Shaft kit, and Model 0928 3/4 inch Single Shaft kit.



Matched Bodine UPM Speed Controls

Our UPM speed controls can drive SCR rated gearmotors with power rating of up to 1/5 HP. Model 0865 or 0866 (chassis), and model 1865 (NEMA-4) provide basic speed control from either a 115VAC or 230VAC power source. Each features six DIP switches for quick system configuration to match the motor HP to the control. The chassis controls are available with either 1/2" quick connect tabs or plug-in terminal connections. Check our [web site](#) and control user manual for maximum allowable HP.