



Wash-Down Stainless Steel Worm Gearmotors

Rated IP-69K for protection against dust and high temperature, high pressure water ingress.

Our new stainless steel worm gearmotors are rated IP-69K, and are ideal for machines and systems that are subject to particularly intensive cleaning. Regardless of whether the gearmotors are used for materials handling, intralogistics or clean applications, their hygienic properties, long operating life and low maintenance make them particularly well suited to production conditions in the food and beverage industry, pharmaceutical industry, and in permanently wet environments. This product also meets EU Hygienic standard for food machinery.

- Large water tight terminal box in 12 o'clock position for easy access.
- 230/460VAC, 1/2 HP inverter-duty, 3-phase winding
- Torque range: from 158 to 638 lb-in
- Speed range: from 29 to 176 rpm
- Food grade lubricant



Type 56R1BSPP-50JW/H stainless steel hollow shaft gearmotor

Typical Applications

Typical applications include conveyor systems, food processing equipment, pharmaceutical manufacturing machinery and applications where hygiene and cleanliness are critical.

Variable Speed—Stainless Steel Inverter-Duty AC Right Angle Worm Gearmotors

Fixed Speed Rating					Variable Speed (SOA) Ratings ¹							Radial Load ² (lbs.)	Product Type	230/460 VAC Model Number
Speed (rpm)	Torque (lb-in.)	Motor HP	Current (Amps)	Gear Ratio	Speed Range (rpm)	Frequency Range (Hz)	Torque Type	Torque @ 10 Hz (lb-in.)	Torque @ 60 Hz (lb-in.)	Torque @ 90 Hz (lb-in.)				
29	594	1/2	1.6 / 0.78	60	4.6-44	10-90	Variable	345	594	348	823	56R1BSPP-50JW/H	9006	
35	638			50	5.5-53			330	638	322	767		9005	
44	499			40	6.9-66			304	499	286	719		9004	
59	368			30	9.2-88			268	368	239	647		9003	
88	274			20	14-132			210	274	176	569		9002	
176	158			10	28-264			88	158	97	447		9001	

¹ SOA: Contact the factory for detailed speed/torque information (Safe Operating Area).

² The radial (overhung) load ratings are calculated at 20mm (.787 in) from the end of the shaft on either side.



Type 56R1BSPP-50JW Stainless Steel AC Inverter-Duty Gearmotors

Dimensions are in inches

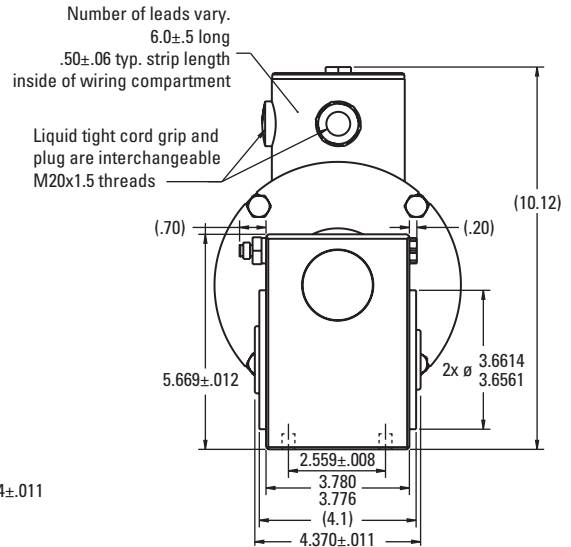
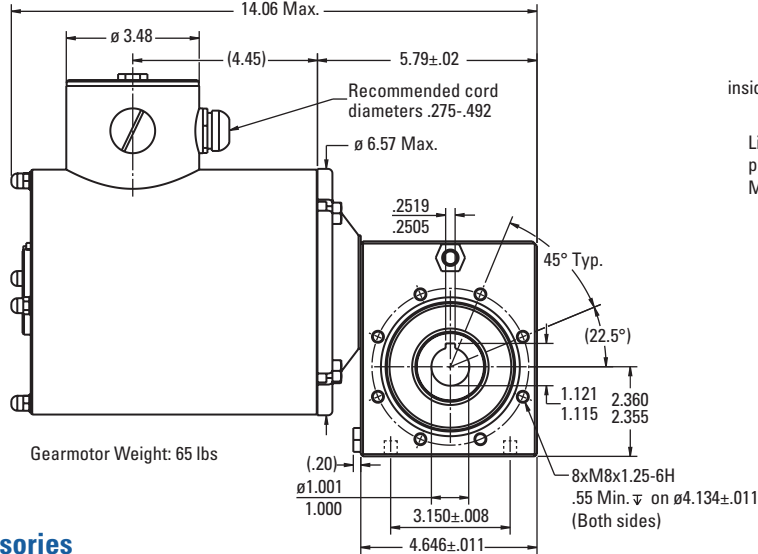

Accessories



More Gearmotors for Challenging Environments



Type 34B/SR-WX
(IP-44)



24A-60P
(IP-66 with flange seal kit)



Type 34R-FX AC
(IP-44)



**Type 34R-FX AC and
Type 34B-FX BLDC**
(IP-66)

- **IP-44:** protected from splashes of water (type 34R-FX AC fixed and variable speed gearmotors and type 34B/SR-WX BLDC INTEGRAmotors).
- **IP-66:** protected from dust ingress and powerful water jets (type 24A-60P PMDC planetary gearmotors, with IP-66 flange mount kit installed.)
- **Class I, Division 2:** for environments where flammable gases or vapors may be spilled or leak (fixed and variable speed type 34R-FX AC; type 34B/SR-WX BLDC INTEGRAmotors).
- **Class I, Division 1:** for environments where ignitable concentrations of flammable gases, vapors or liquids are likely to exist (type 34R-FX AC inverter-duty; type 34B-FX BLDC).

Visit bodine-electric.com to learn more